

## SFP+ 16G 850nm 100m SR

GS-16G85-SR



### Overview

GS-16G85-SR SFP+ transceivers, according to 16 Gigabit Small Form Factor Pluggable “SFP+” Multi-Sourcing Agreement (MSA) SFF-8431 Rev. 4.1 and SFF-8472 Rev. 11.0, are designed for use in Fibre Channel links up to 14.025Gb/s data rate over multimode fiber. They are compatible with FC-PI-5 Rev. 6.00, SFF-8081 and SFF-8432.

GS-16G85-SR offer commercial operating temperature option.

### Features

- ◆ Up to 14.025Gb/s bi-directional data links
- ◆ Electrical interface specifications per SFF-8431
- ◆ Management interface specifications per SFF-8432 and SFF-8472
- ◆ Build-in Dual CDR at 14.025Gb/s and bypass at 4.25Gb/s and 8.5Gb/s
- ◆ SFP+ MSA package with duplex LC connector
- ◆ Uncooled 850nm VCSEL Laser
- ◆ 35m on 50/125um MMF
- ◆ 100m on high-bandwidth 50/125um(OM3) MMF
- ◆ Single +3.3V power supply
- ◆ Class 1 laser safety certified
- ◆ Metal enclosure, for lower EMI
- ◆ Operating case temperature: 0 to 70 °C
- ◆ RoHS Compliant

### Applications

- ◆ Tri Rate 4.25 / 8.5 / 14.025 Gb/s Fibre Channel Rate

### Ordering Information

Part Number	Product Description
GS-16G85-SR	SFP+ 16Gbps, 850nm, 100m, 0°C ~ +70°C

## Absolute maximum rating

Stresses in excess of the absolute maximum ratings can cause permanent damage to the device. These are absolute stress ratings only. Functional operation of the device is not implied at these or any other conditions in excess of those given in the operational sections of the data sheet. Exposure to absolute maximum ratings for extended periods can adversely affect device reliability.

Parameters	Symbol	Min.	Max.	Unit
Power Supply Voltage	$V_{CC}$	-0.5	4.0	V
Storage Temperature	$T_c$	-40	+85	°C
Relative Humidity	RH	5	95	%

## Recommended Operating Condition

Parameter	Symbol	Min.	Typical	Max	Unit
Power Supply Voltage	$V_{CC}$	3.135	3.300	3.465	V
Operating Case Temperature	$T_c$	0	25	70	°C
Data Rate	-	-	4.25/8.5/14.025		Gb/s

## Transceiver Electrical Characteristics

Parameter	Symbol	Minimum	Typical	Maximum	Unit	Notes	
Module Supply Current	$I_{CC}$	-		300	mA	-	
Power Dissipation	$P_D$	-	-	1000	mW	-	
<b>Transmitter</b>							
Input Differential Impedance	$Z_{IN}$	-	100	-	$\Omega$	-	
Differential Data Input Swing	$V_{IN, P-P}$	180	-	700	mV <sub>p-p</sub>	-	
TX_FAULT	Transmitter Fault	$V_{OH}$	2.0	-	$V_{CC}$	V	TX_FAULT
	Normal Operation	$V_{OL}$	0	-	0.8	V	
TX_DISABLE	Transmitter Disable	$V_{IH}$	2.0	-	$V_{CC}$	V	TX_DISABLE
	Transmitter Enable	$V_{IL}$	0	-	0.8	V	
<b>Receiver</b>							
Output Differential Impedance	$Z_O$	-	100	-	$\Omega$	-	
Differential Data Output Swing	$V_{OUT, P-P}$	300	-	850	mV <sub>p-p</sub>	1	
Data Output Rise Time, Fall Time	$t_r, t_f$	-	30	-	ps	2	
RX_LOS	Loss of signal (LOS)	$V_{OH}$	2.0	-	$V_{CC}$	V	RX_LOS
	Normal Operation	$V_{OL}$	0	-	0.8	V	3

### Notes:

1. Internally AC coupled, but requires an external 100 $\Omega$  differential load termination.
2. 20 – 80 %.
3. LOS is an open collector output. Should be pulled up with 4.7k $\Omega$  on the host board.

## Transmitter Optical Characteristics

Parameter	Symbol	Minimum	Typical	Maximum	Unit	Notes
Launch Optical Power	P <sub>o</sub>	-6	-2.5	-1.2	dBm	1
Center Wavelength Range	λ <sub>c</sub>	840	850	860	nm	-
Optical Modulation Amplitude @ 4.25 Gb/s	OMA	247	-	-	uW	
Optical Modulation Amplitude @ 8.5 Gb/s	OMA	302	-	-	uW	
Optical Modulation Amplitude @ 14.025 Gb/s	OMA	331	-	-	uW	
Optical Rise/Fall Time @ 4.25 Gb/s	t <sub>r</sub> /t <sub>f</sub>			90	ps	2
Transmitter Waveform and Dispersion Penalty @ 8.5 Gb/s	TWDP	-	-	4.3	dB	3
Spectral Width (RMS) @14.025Gb/s	Δλ	-	-	0.59	nm	-
Optical Return Loss Tolerance	ORLT	-	-	12	dB	-
Pout @TX-Disable Asserted	P <sub>off</sub>	-	-	-30	dBm	1
Launch Optical Power	P <sub>o</sub>	-6	-2.5	-1.2	dBm	1

**Notes:**

1. 50/125μm fiber with NA = 0.2, 62.5/125μm fiber with NA = 0.275.
2. Unfiltered, 20-80%. Complies with FC 1x and 2x eye mask when filtered.
3. TWDP is calculated with a 1,0 equalizer and a 9.84 GHz Gaussian filter for the fiber simulation. Jitter values at γT and γR are controlled by TWDP and stress receiver sensitivity.

## Receiver Optical Characteristics

Parameter	Symbol	Minimum	Typical	Maximum	Unit	Notes
Center Wavelength	λ <sub>c</sub>	840	-	860	nm	-
Receiver OMA Sensitivity = 4.25 Gb/s	RxSENS	-	-	-12.1	dBm	1
Receiver OMA Sensitivity = 8.5 Gb/s	RxSENS	-	-	-11.2	dBm	1
Receiver OMA Sensitivity = 14.025 Gb/s	RxSENS	-	-	-10.5	dBm	2
Receiver Overload (P <sub>avg</sub> )	P <sub>OL</sub>	0	-	-	dBm	
Optical Return Loss	ORL	12	-	-	dB	-
LOS De-Assert	LOS <sub>D</sub>	-	-	-13	dBm	-
LOS Assert	LOS <sub>A</sub>	-30	-	-	dBm	-
LOS Hysteresis	-	0.5	-	-	dB	-

**Notes:**

1. Measured with PRBS 2<sup>7</sup>-1 at 10<sup>-12</sup> BER, Unstress sensitivity.
2. Measured with PRBS 2<sup>31</sup>-1 at 10<sup>-12</sup> BER, Unstress sensitivity.

## General Specifications

Parameter	Symbol	Minimum	Typical	Maximum	Unit	Notes
Data Rate	BR		4.25 8.5 14.025		Gb/s	1
Bit Error Rate	BER			10 <sup>-12</sup>		2
Fiber Length on 50/125µm MMF	L	-	-	150 50 35	m	3 4 5
Fiber Length on 50/125µm high-bandwidth (OM3) MMF	L	-	-	380 150 100	m	3 4 5

### Notes:

1. 4x and 8x Fibre Channel compatible, per FC-PI-4.
2. PRBS 2<sup>7</sup>-1 for 4GFC and 8GFC. PRBS 2<sup>31</sup>-1 for 16GFC.
3. At 4.25 Gb/s Fibre Channel data rate.
4. At 8.5 Gb/s Fibre Channel data rate.
5. At 14.025 Gb/s Fibre Channel data rate.

## Pin Definition

Pin	Symbol	Name/Description	Note
1	VEET	Transmitter Ground	1
2	TX_Fault	Transmitter Fault (LVTTTL-O) - High indicates a fault condition	2
3	TX_Disable	Transmitter Disable (LVTTTL-I) – High or open disables the transmitter	3
4	SDA	Two wire serial interface Data Line (LVCMOS-I/O) (MOD-DEF2)	4
5	SCL	Two wire serial interface Clock Line (LVCMOS-I/O) (MOD-DEF1)	4
6	MOD_ABS	Module Absent (Output), connected to VeeT or VeeR in the module	5
7	RS0	Rate Select 0 – Not used, Presents high input impedance	6
8	RX_LOS	Receiver Loss of Signal (LVTTTL-O)	2
9	RS1	Rate Select 1 – Not used, Presents high input impedance	6
10	VeeR	Receiver Ground	1
11	VeeR	Receiver Ground	1
12	RD-	Inverse Received Data out (CML-O), AC Coupled	-
13	RD+	Received Data out (CML-O), AC Coupled	-
14	VeeR	Receiver Ground	-
15	VccR	Receiver Power - +3.3V	-
16	VccT	Transmitter Power - +3.3 V	-
17	VEET	Transmitter Ground	1
18	TD+	Transmitter Data In (CML-I), AC Coupled	-
19	TD-	Inverse Transmitter Data In (CML-I), AC Coupled	-
20	VEET	Transmitter Ground	1

**Notes:**

1. The module signal grounds are isolated from the module case.
2. This is an open collector/drain output that on the host board requires a 4.7KΩ to 10KΩ pull-up resistor to VccHost.
3. This input is internally biased high with a 4.7KΩ to 10KΩ pull-up resistor to VccT.
4. Two-Wire Serial interface clock and data lines require an external pull-up resistor dependent on the capacitance load.
5. This is a ground return that on the host board requires a 4.7KΩ to 10KΩ pull-up resistor to VccHost.
6. Rate select can also be set through the 2-wire bus in accordance with SFF-8472 v. 11.0, Rx Rate Select is set at Bit 3, Byte 110, Address A2h. Tx Rate Select is set at Bit 3, Byte 118, Address A2h.

**Note:** writing a “1” selects maximum bandwidth operation. Rate select is the logic OR of the input state of Rate Select Pin and 2-wire bus.

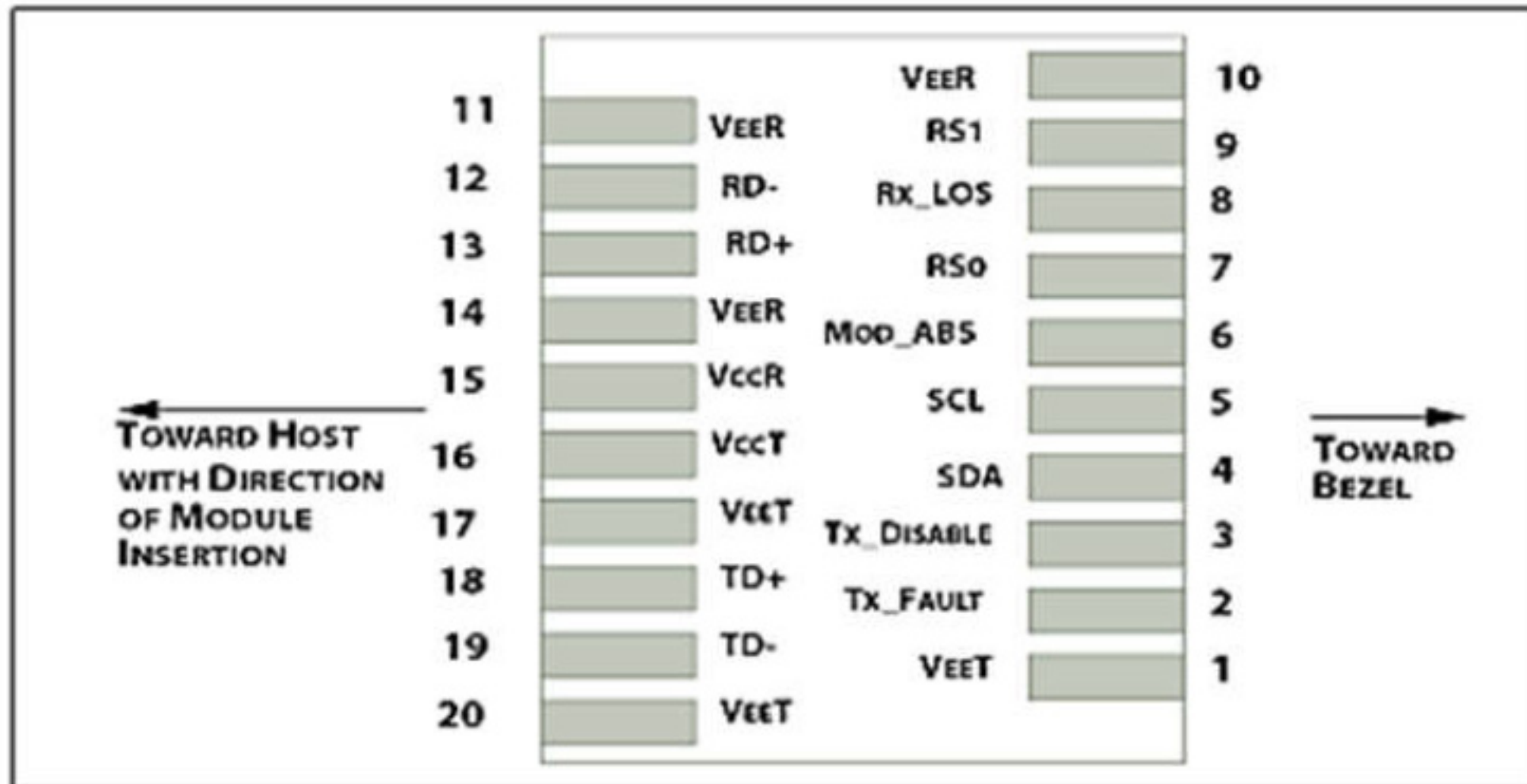

Figure 1: Interface to Host PCB

### Recommended Host Board Power Supply Filter Network

Figure2. Recommended Host Board Power Supply Filter Network

## Recommended Application Interface Block Diagram

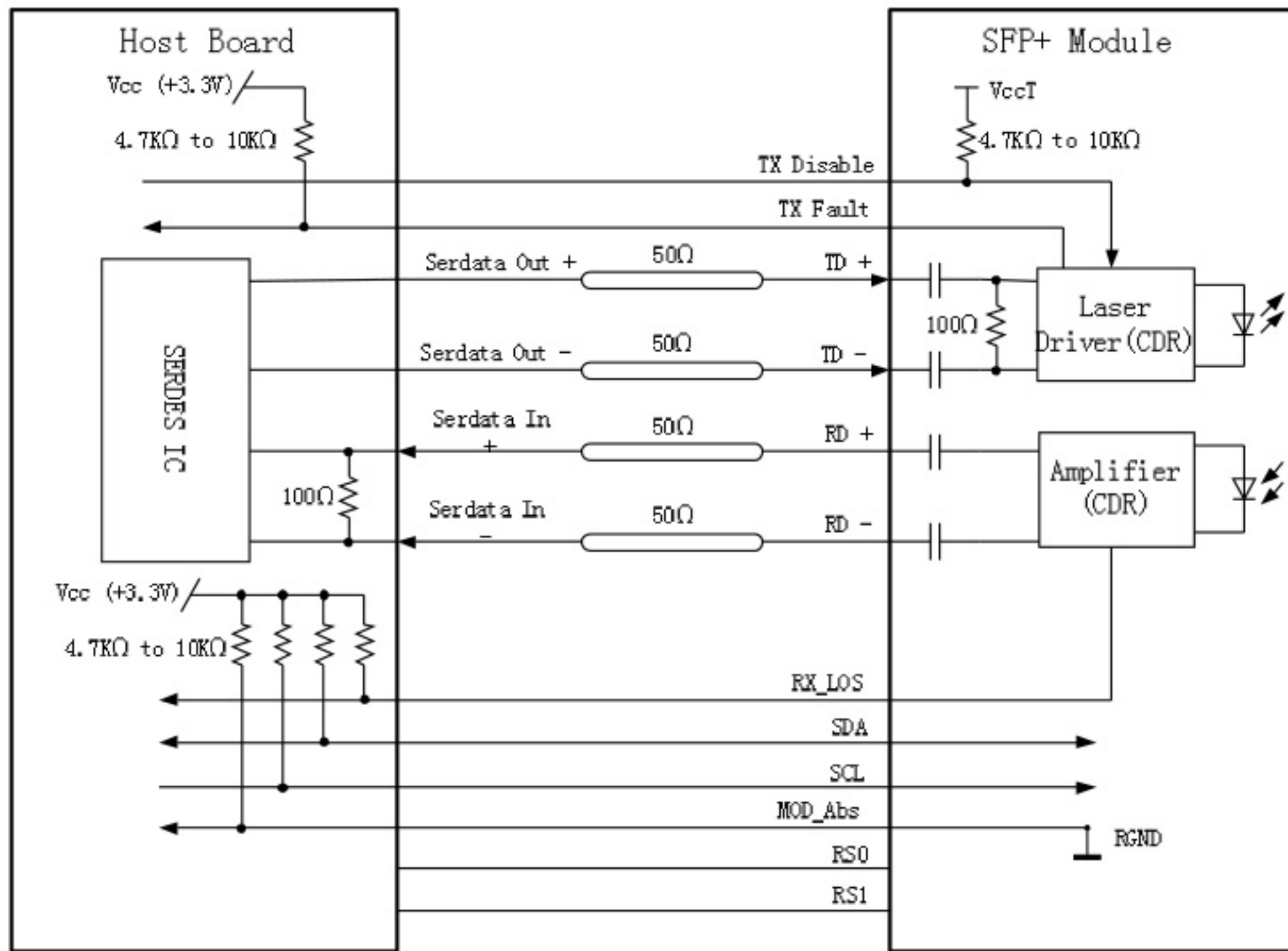

Figure3. Recommended Application Interface Block Diagram

## Mechanical Specifications

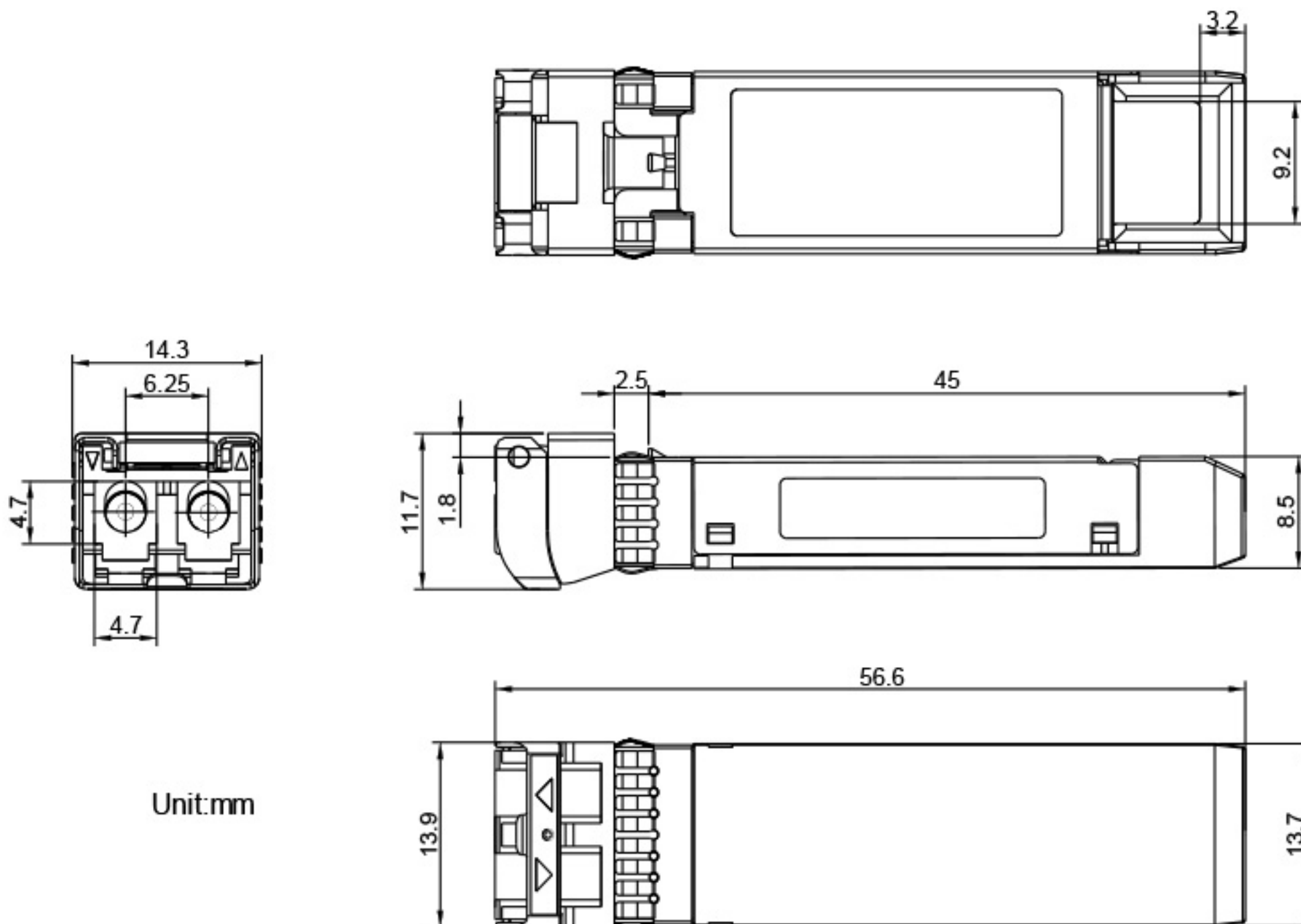

Figure4. Mechanical Specifications

